



Agile, Versatile, Ready



Agiles, Polyvalents, Prêts

Canadian Forces  
Disaster Assistance Response Team  
(DART)

Major Michael Percy  
Deputy Commanding Officer  
Task Force Philippines

# AIM

To provide an overview of the Canadian  
Armed Forces DART and OP  
RENAISSANCE 13-01 (Philippines)



# AGENDA

- Key documents
- CAF HADR principles
- DART employment parameters
- Employment concepts
- DART Capabilities
- RENAISSANCE Concept
- Readiness postures
- DART History
- OP RENAISSANCE 13-01

## KEY DOCUMENTS

- CDS Directive on HADR
- CJOC Contingency Plan  
(CONPLAN) RENAISSANCE
- GoC SOPs in Response to Natural  
Disasters Abroad



# CAF HADR PRINCIPLES

- CAF is only one of several GoC response options
- Any response is underpinned by the international humanitarian principles of neutrality, humanity and impartiality
- CAF response should compliment and not replace existing relief mechanisms
- Any response has the mission of saving lives and reducing human suffering



# DART

- DART is the CAF's most likely initial response to a natural disaster
- ***DART is not a standing unit***, but a core group of CAF capabilities held at high readiness
- Most DART equipment, stores and supplies are held at the High Readiness Detachment in Trenton
- DART personnel are brought together periodically for training
- One DART only.



## EMPLOYMENT PARAMETERS

- Decision to deploy the DART rests with the GoC
- DFATD is the response lead, CAF is in a partnering and supporting role
- DART must be integrated with our WoG partners during training and on operations
- CO DART reports to military Comd upon deployment, but supports the Head of Mission
- DART personnel must be maintained at high readiness
- DART personnel must be enabled by well maintained, appropriate HADR equipment.





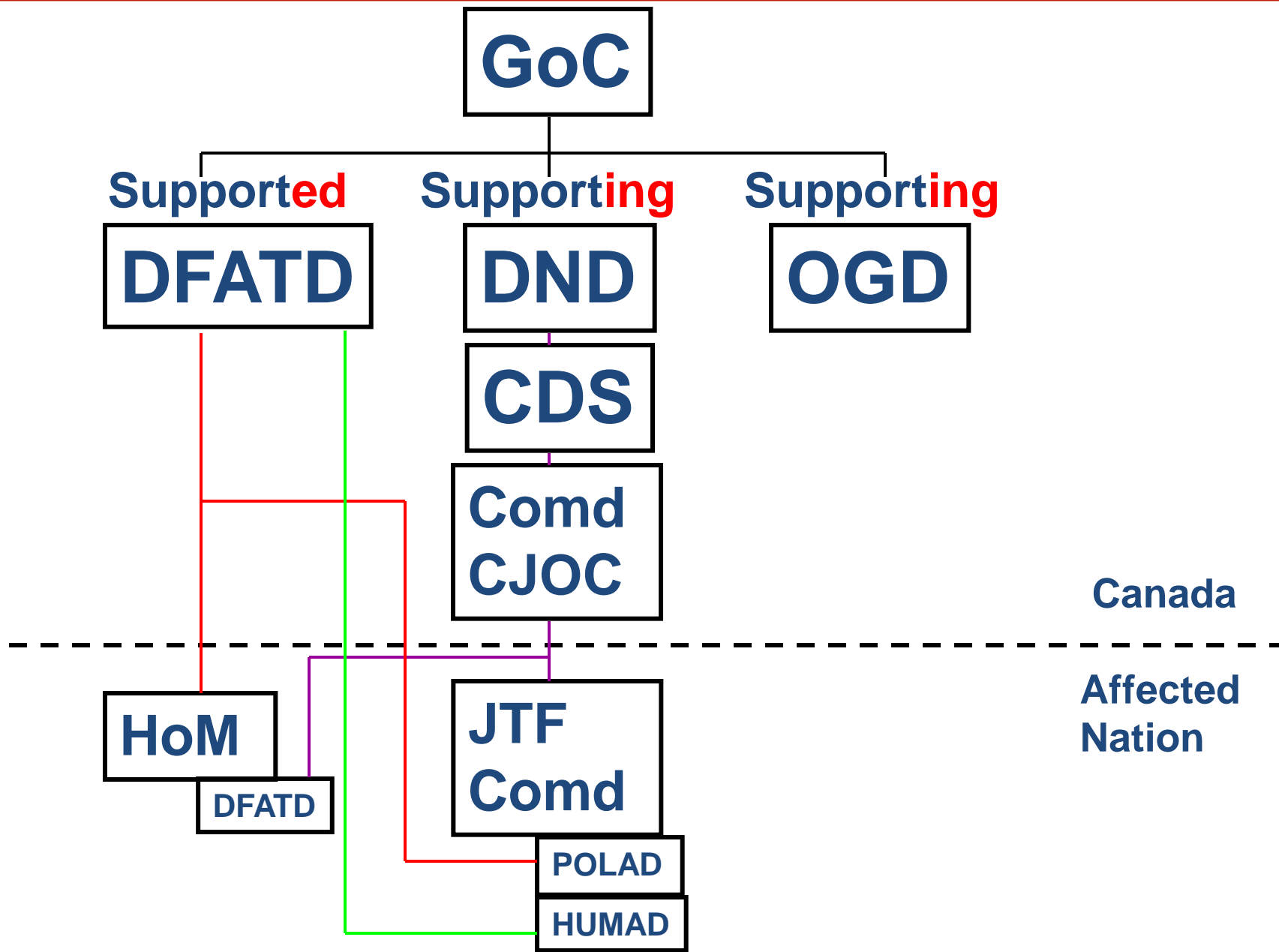

**Inter-departmental Strategic Support Team (ISST)**  
5 Pers

# ISST AND HART

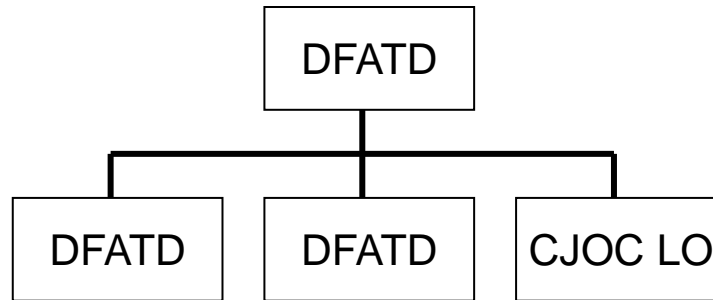

**Humanitarian Assistance Reconnaissance Team (HART)**  
15 Pers

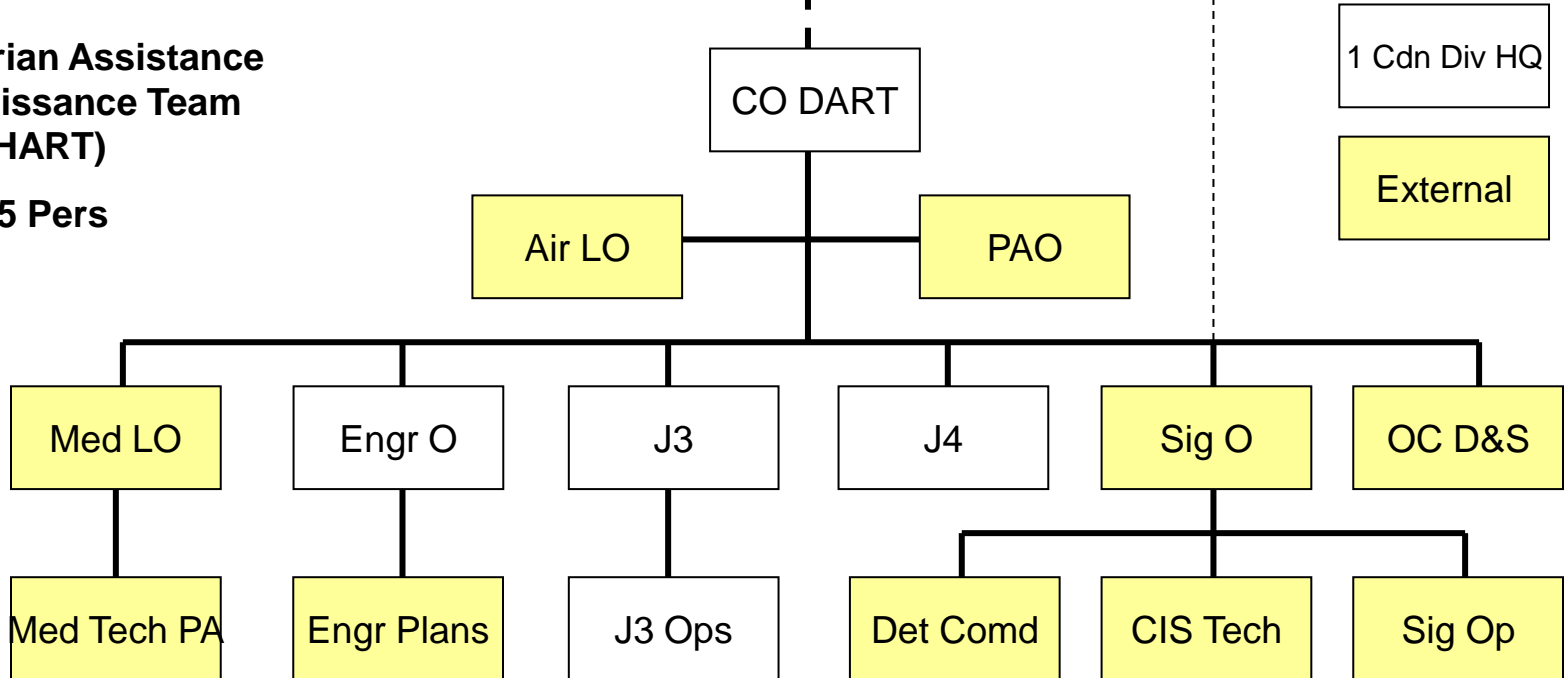

# DART CAPABILITIES

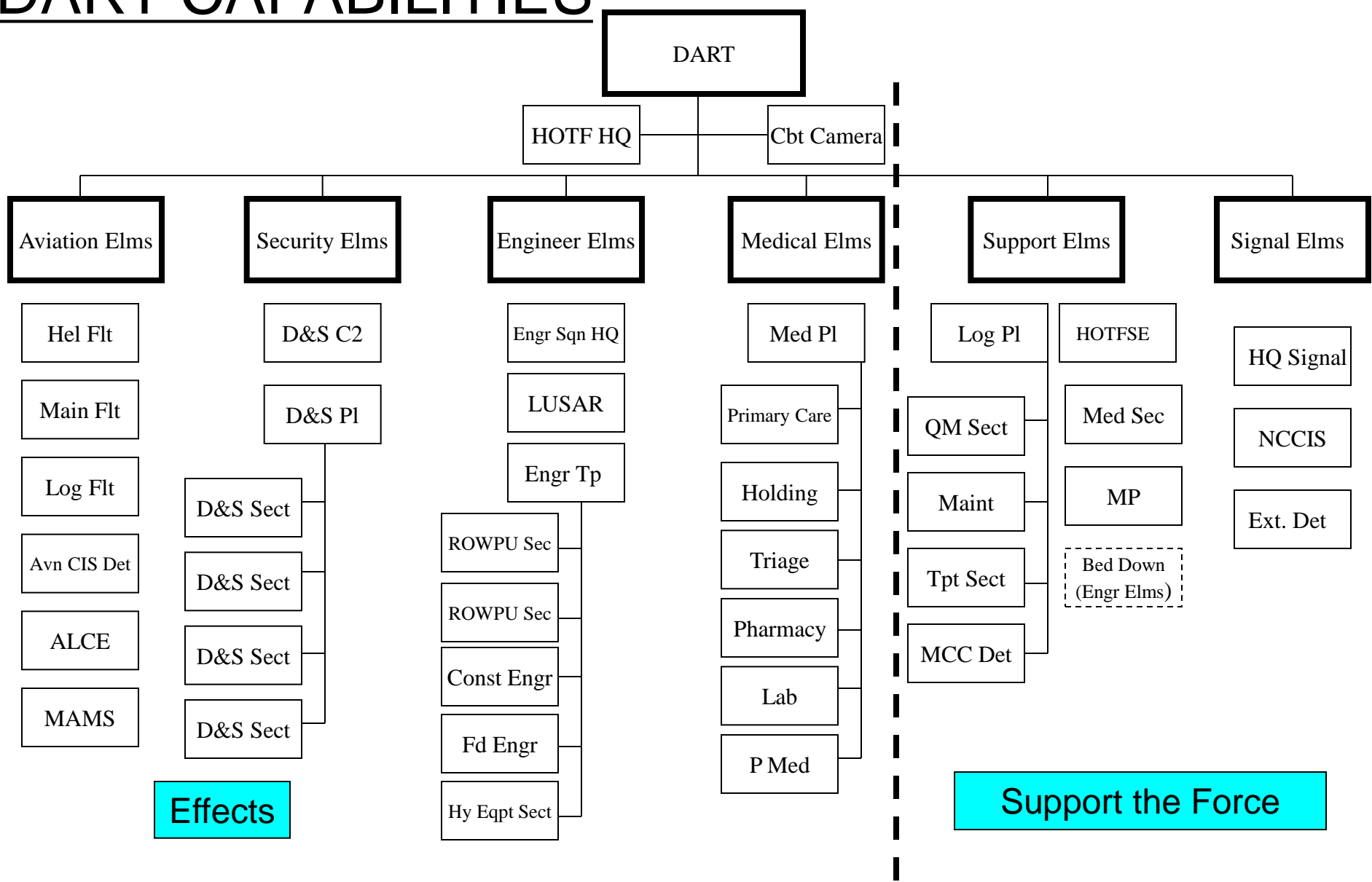

Effects

Support the Force

# RENAISSANCE CONCEPT

Disaster Response Stages

GoC Tasking to CAF

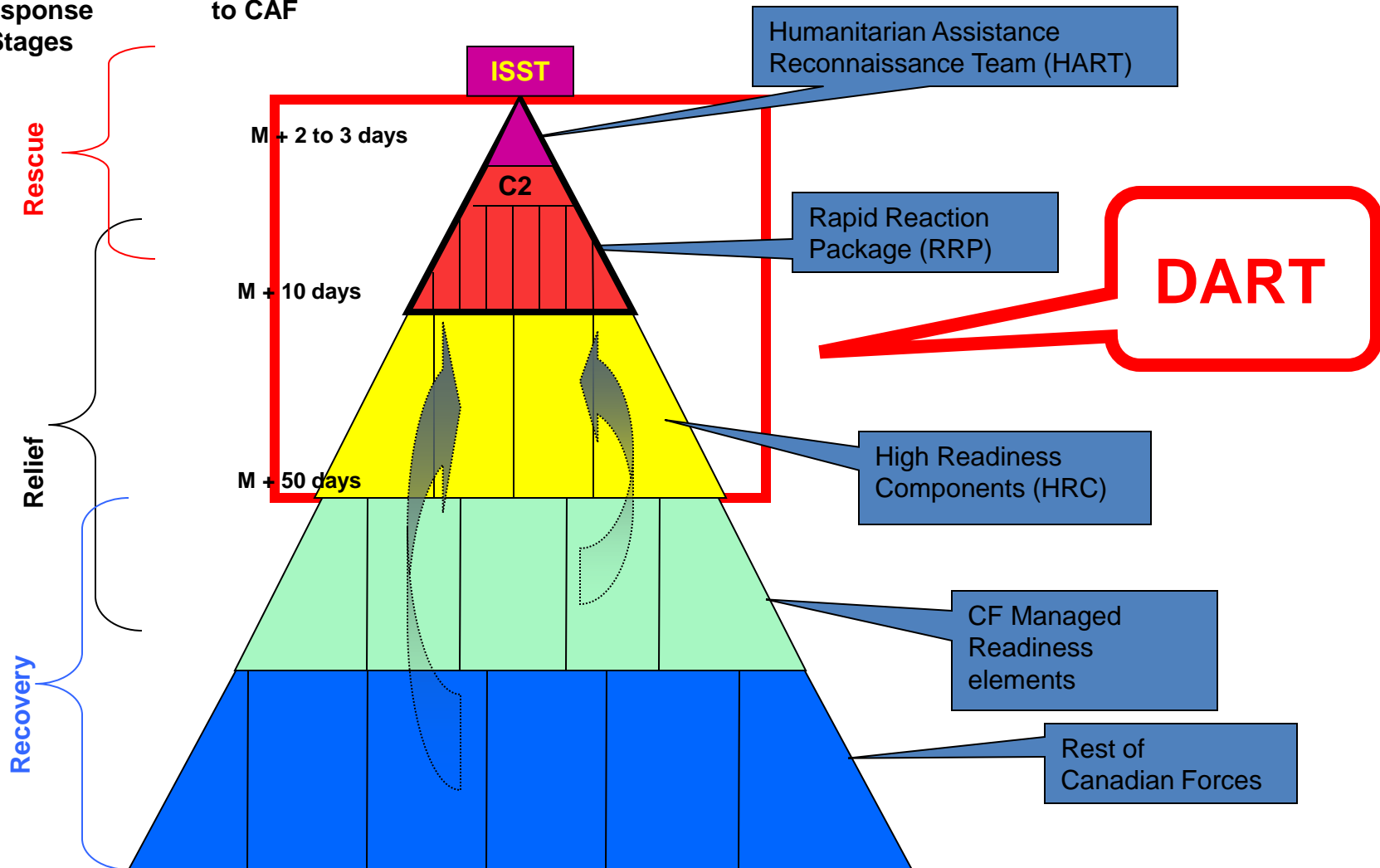

# Means of Last Resort

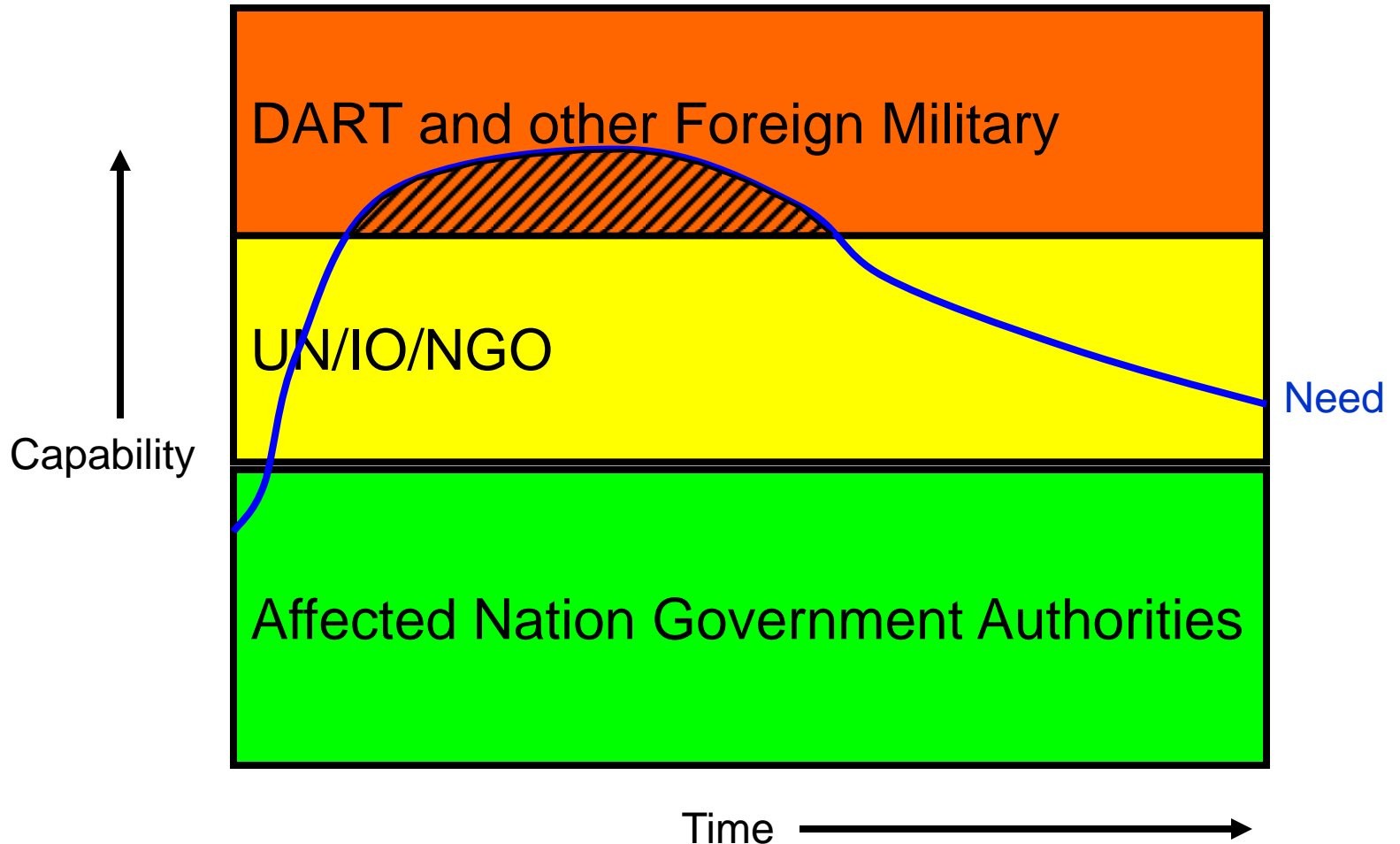



# READINESS POSTURE



- **12 hrs NTM**
  - Interdepartmental Strategic Support Team (ISST)
  - Humanitarian Assistance Reconnaissance Team (HART)
- **48 hrs NTM**
  - Rapid Reaction Package Modules
  - High Readiness Components
- **Equipment**
  - Most Equipment and Material pre-positioned at the High Readiness Detachment Trenton
  - Established and equipped for a planned 40 days in theatre

# History

- Honduras 1998 (Op CENTRAL): Hurricane Mitch
- Turkey 1999 (Op TORRENT): 7.6 Earthquake
- Sri Lanka 2004/05 (Op STRUCTURE): Indian Ocean Tsunami
- Pakistan 2005 (Op PLATEAU): 7.6 Earthquake
- Haiti 2008 (Op HORATIO): Hurricane Gustav
- Haiti 2010 (Op HESTIA): 7.0 Earthquake
- Philippines 2013 (Op RENAISSANCE 13-01): Typhoon Haiyan



# Op RENAISSANCE Panay Island, Philippines Nov-Dec 2013



# Significant Events

- Kingston: Zulu - 5 hours
  - Manila: Zulu + 8 hours
- NOTE: 13 hours difference

**This was not Haiti**

**End Mission  
15 Dec 13**

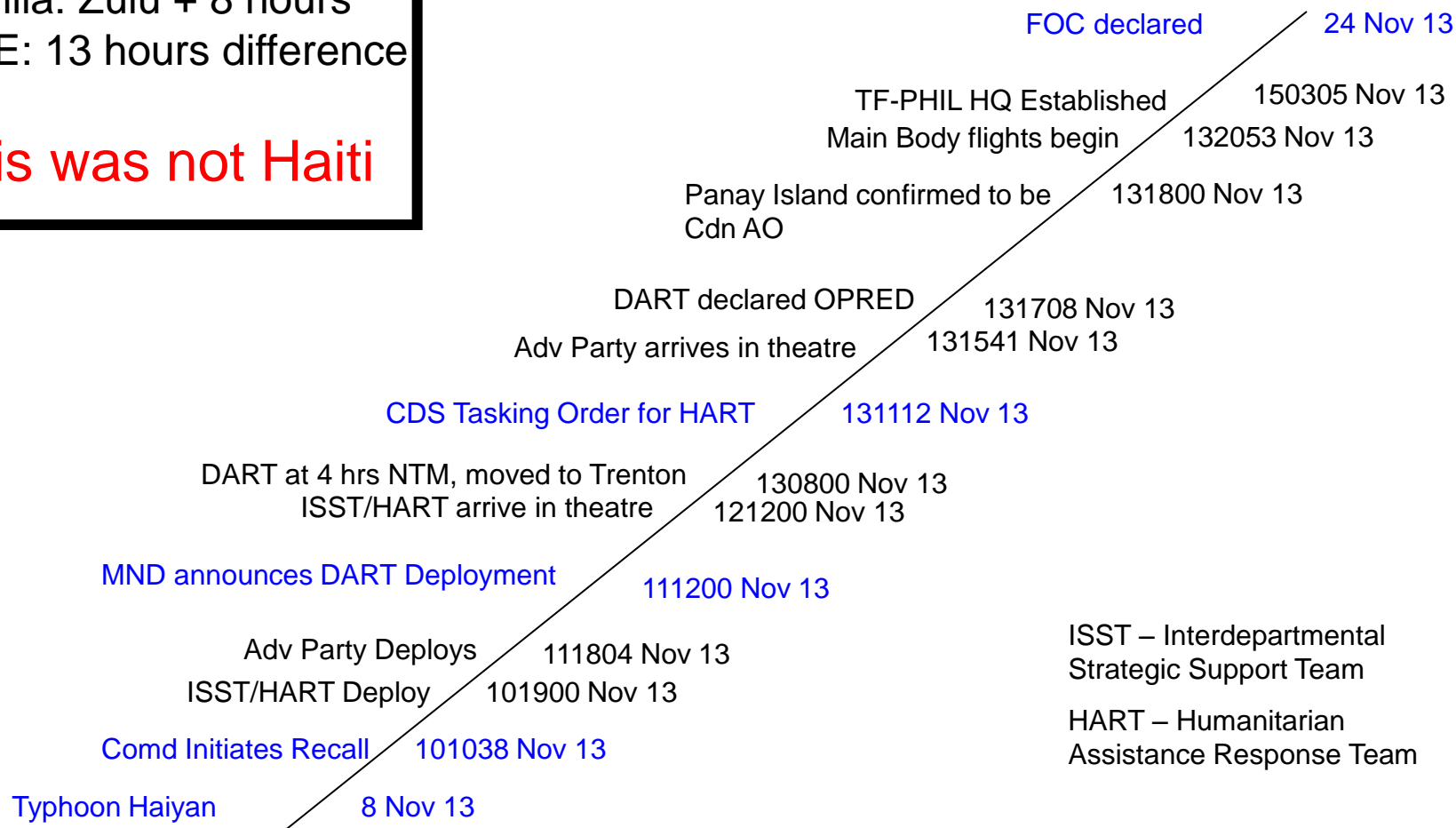

# JTF-Philippines MISSION

JTF-PHILIPPINES will enable the provision of humanitarian assistance to the affected population on PANAY Island, PHILIPPINES, commencing 11 Nov 13 in order to save life and reduce human suffering until such a time as HN and humanitarian partners are able to meet assessed needs to pre-Typhoon standards.



# Philippines



# Typhoon Haiyan

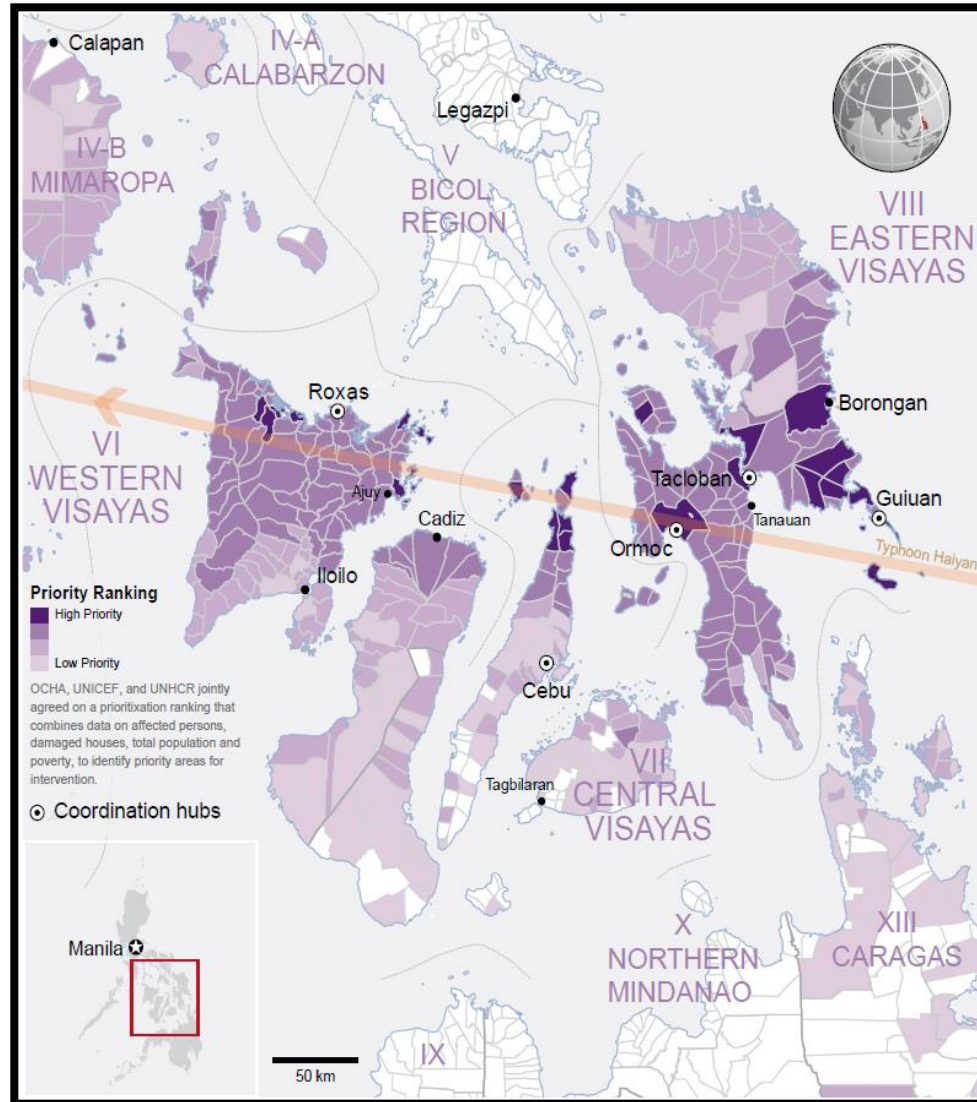



# Panay Island

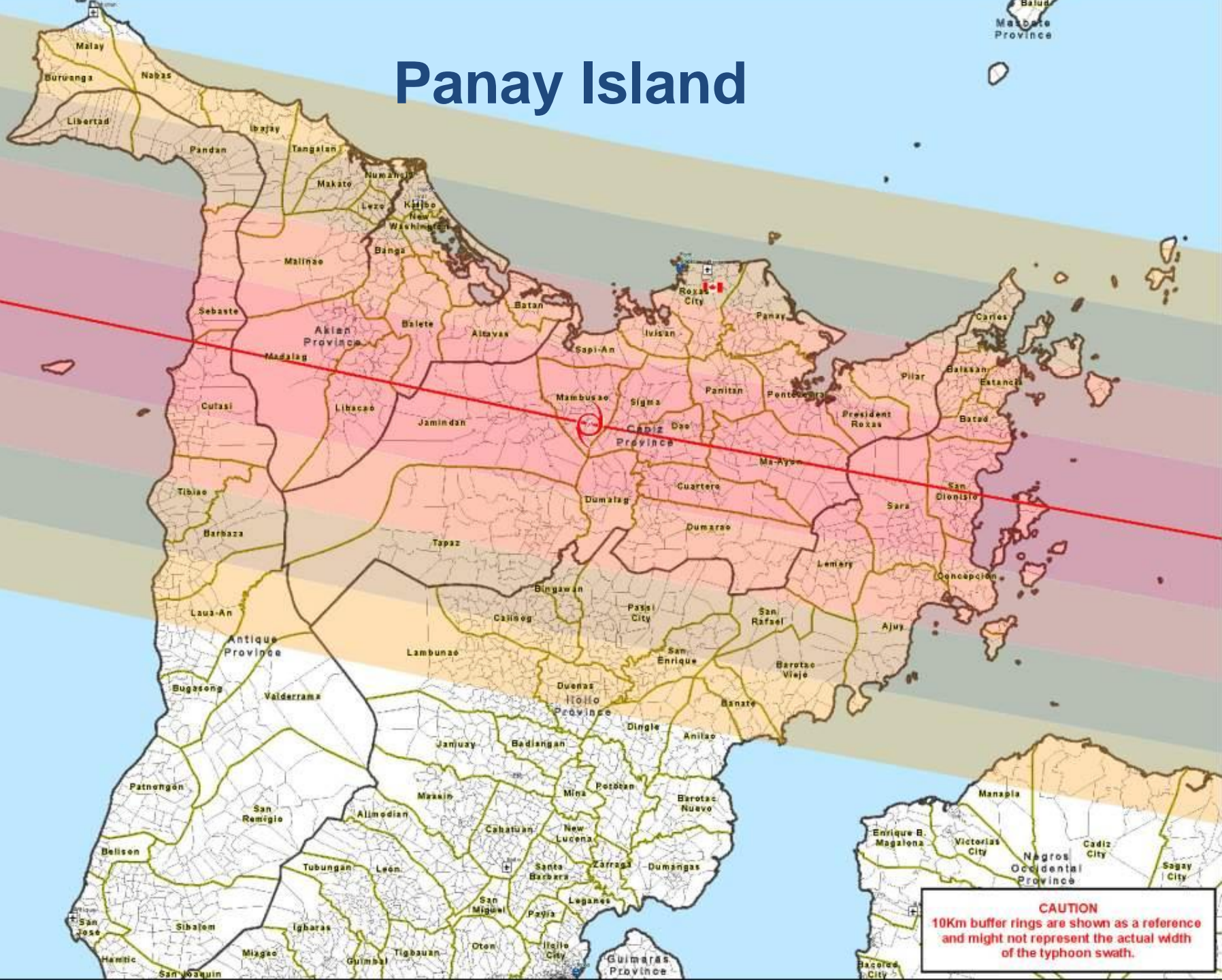

**CAUTION**  
10km buffer rings are shown as a reference and might not represent the actual width of the typhoon swath.



# Damage



- 2.8 Million people affected
- 241,738 homes totally destroyed
- 256,302 homes partially damaged
- \$50 million damage to schools
- \$30 million damage to agriculture
- \$30 million damage to fishery
- \$2.5 million damage to hospitals/clinics
- 800,000 liters oil spilled in Estancia





# DART INFLUENCED BARANGAYS

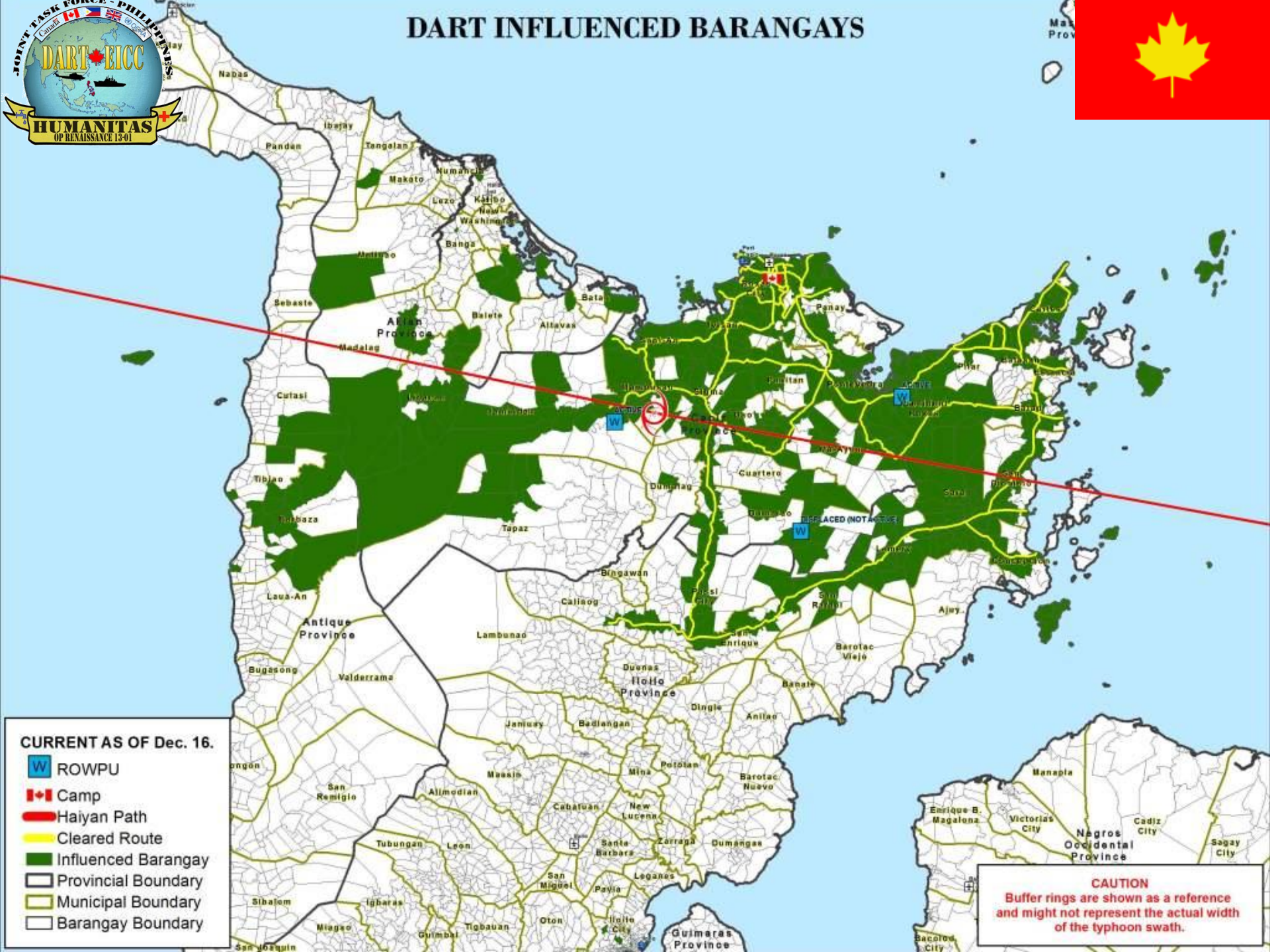

CURRENT AS OF Dec. 16.

- ROWPU
- Camp
- Haiyan Path
- Cleared Route
- Influenced Barangay
- Provincial Boundary
- Municipal Boundary
- Barangay Boundary

**CAUTION**  
Buffer rings are shown as a reference  
and might not represent the actual width  
of the typhoon swath.



# Overall Accomplishments

- 6600 patients treated
- 519,000 litres of potable water
- 290,000 lbs of food delivered
- 10,325 lbs of building materials delivered
- 2,688 x Non-Food Items (Water/Wash/Hygiene kits) delivered
- 27 water purification systems delivered
- 131 kms of routes cleared from debris
- 8 hospital generators repaired
- 2,500 person evacuation camp built
- 133 media interviews conducted
- Produced 1.2 km of maps

# Armed Forces of the Philippines





# Filipino Canadians





# Aviation





# Engineers





# Medical



# Coordination Environment

## Manila

NDRRMC  
Cdn Embassy  
MNCC

## Kalibo

Aklan Provincial Govt  
PDRRMC

## Roxas City

### DART

Capiz Provincial Government  
PDRRMC  
3<sup>rd</sup> Inf Div HQ  
Dept of Social Welfare  
UN OCHA  
40 x IO, NGO, UN Agency  
Royal Navy Liaison Det  
Municipal Government

## Iloilo City

Iloilo Provincial Govt  
RDRRMC  
PDRRMC  
Airport Authority

## San Jose

Antique Provincial Govt  
PDRRMC

- Philippines Governmental
- International Civilian
- International Military



# Coordination



# Coordination



“This is the most effective civil-military coordination we have ever seen at the field level and should be used as a model for future disaster response operations”

Baroness Valerie Amos UN Under Secretary General for Humanitarian Affairs

# Lessons Learned

- Geomatics
- Water Supply Operations
- Embassy/Defence Attaché
- Strategic Airlift
- Sustainment
- Authorities

# DART CONTACTS

- LCol Ed Izatt, Commanding Officer (designate)
  - [Ed.Izatt@forces.gc.ca](mailto:Ed.Izatt@forces.gc.ca)
  - 613-541-5010 ext 4121
  
- Maj Chris Strain, Deputy Commanding Officer (designate)
  - [Chris.Strain@forces.gc.ca](mailto:Chris.Strain@forces.gc.ca)
  - 613-541-5010 ext 7542



# QUESTIONS?





Agile, Versatile, Ready



Agiles, Polyvalents, Prêts